

DOUGLAS **SBD-5** DAUNTLESS

WINGSPAN : 1330MM (53-3/8")

User Manual



- The manual suit for every color scheme of Freewing Douglas SBD-5 Dauntless.
- The manual only choose one color scheme as an example.
- The manual is only for reference, all is according to the actual product. We can't note if any improvement or upgrade.
- 此说明书适合本公司 SBD-5 Dauntless 所有涂装安装指导。
- 此说明书仅选用其中一款涂装作为范本进行安装指导。
- 说明书仅作参考,一切以实物为准。为产品改进而进行的版本升级,不另行通知!

Welcome to purchase our Freewing Douglas SBD-5 dauntless dive bomber. In the U.S. Navy during WW II ,Douglas SBD-5 dauntless dive bomber is one of main carrier-based bombers which active in the Pacific theater. SBD-5 unique “perforated air brake flaps” increased the stability largely of fuselage dive. As its name suggests,in Pacific theater, with no fear and the spirit of courage, in the Battle of Coral Sea and Battle of Midway, driving SBD-5 pilots sank the Japenese proud Marine Main: Akagi,Kaga,black dragon, dragon,four aircraft carrier, set an unprecedented record.

Based on the physical prototypes, we designed and produced this SBD-5 model plane. We use EPO material and also add carbon material to strengthen its structure. Excellent structure design makes that its very easy and simple to assemble. We only need ten minutes to complete its assemble.

This is very high scale SBD-5, we produced a lot of detail on the prototype aircraft, especially flap part. Indeed, the effect of SBD unique perforated air brake flaps is obviously for the stability of fuselage dive.

The following is our basic specification.

Specification	
Material	EPO
Wingspan	1330mm (53-3/8")
Fuselage Length	1040mm (41")
Flying Weight	1750g (61.72 oz.)
Motor Size	3648-600KV
Prop Size	3-Bladed 12*7
Recommended Battery	4S 14.8V 2200mAh 25C
ESC	40A ESC (1pcs)
Servos	6pcs 9g servo.
Retracts	Scale Electric Retract
Landing gear cabin door control	No
Aileron	YES
Elevator	YES
Rudder	YES
Throttle	YES
Flaps	YES

At the same time, we provide three kinds of configuration options (RTF. PNP. Airframe), please according to the configuration list, refer to the following pictures to check the products and their accessories.



Accessory Bag Content List

ARF Version

Parts bag 1

No.	Name	Specification	Qty.
1	Screw	PA 3*35mm	4
2	Screw	PA 3*42mm	3
3	Screw	PA 3*50mm	1
4	Screw	PM 2*16mm	1
5	Screw	PT 1.7*16mm	1
6	Lock Nut	M2.0	2

Parts bag 2

No.	Name	Specification	Qty.
1	Metal Wire	∅0.5mm L=800mm	1

Parts bag 3

No.	Name	Specification	Qty.
1	Y wire	L=100mm	3
2	Chuck	∅1.2mm	2
3	Screw Driver Handle	/	1
4	Screw Driver Head	/	2
5	Spare parts bag	Spare parts bag 1 Spare parts bag 2	2

Parts bag 4

No.	Name	Specification	Qty.
1	Landing Hook	/	1
2	"A" Type Bomb Pylons	/	1
3	Fuselage Antenna	/	1
4	Main wing Antenna	/	1
5	Main wing Fixing Part (Front)	/	1
6	Main wing Fixing Part (Rear)	/	1

Airframe Version

Parts bag 1

No.	Name	Specification	Qty.
1	Screw	PA 3*10mm	4
2	Screw	PA 3*35mm	4
3	Screw	PA 3*42mm	3
4	Screw	PA 3*50mm	1
5	Screw	PM 2*16mm	1
6	Screw	PT 1.7*16mm	2
7	Screw	PWA 2*8mm	4
8	Lock Nut	M2.0	2

Parts bag 2

No.	Name	Specification	Qty.
1	Metal Wire	∅0.5mm L=800mm	1

Parts bag 3

No.	Name	Specification	Qty.
1	Y wire	L=100mm	3
2	Chuck	∅1.2mm	2
3	Screw Driver Handle	/	1
4	Screw Driver Head	/	2
5	LED Controller	/	1
6	Flap Servo Metal Wire	∅0.8mm L=105mm	2
7	Spare Parts Bag	Spare parts bag 1 Spare parts bag 2	2

Parts bag 4

No.	Name	Specification	Qty.
1	Landing Hook	/	1
2	"A" Type Bomb Pylons	/	1
3	Fuselage Antenna	/	1
4	Main wing Antenna	/	1
5	Main wing Fixing Part (Front)	/	1
6	Main wing Fixing Part (Rear)	/	1
7	Nose Cowl	/	1
8	Nose Decorated Cover	/	1

欢迎购买我们的道格拉斯SBD-5无畏式俯冲轰炸机。道格拉斯SBD-5无畏式俯冲轰炸机是美国海军二战时期，活跃在太平洋战场上的主力舰载轰炸机之一。SBD-5独特的“穿孔式空气煞车襟翼”，很大程度上增加了俯冲时的机身稳定性。正如其名，在太平洋战场，驾驶着SBD-5的飞行员凭借毫无畏惧、勇往直前的精神，在珊瑚海海战与中途岛海战中，击沉了日本引以为傲的海上主力：赤城、加贺、苍龙、飞龙四艘航空母舰，创下空前战绩！

我们根据实物原型，设计并生产了这款SBD-5模型。我们采用EPO材料制作，大量使用碳纤材料来加强飞机强度。优秀的结构设计，使得整机有很高的完成度，我们仅仅需要十分钟的时间，来完成飞机的组装。

这是一款像真度非常高的SBD-5，我们制作了大量原型飞机上的细节。特别是襟翼部份。的确，SBD-5独特的“穿孔式空气煞车襟翼”对于俯冲飞行时机身稳定有明显的效果。

关于产品的一些基本参数,请查看以下表格.

基本参数	
制作材料	EPO
翼展长度	1330mm (53-3/8")
机体长度	1040mm (41")
飞行重量	1750g (61.72 oz.)
电机规格	3648-600KV
螺旋桨规格	3叶 12*7
标准配备电池规格	4S 14.8V 2200mAh 25C
电子调速器	40安培无刷电调
舵机	9克舵机 6只
起落架	电动收放起落架
起落架舱门控制	无此功能
副翼控制	标准控制
升降控制	标准控制
方向控制	标准控制
油门控制	标准控制
襟翼控制	标准控制

同时,我们准备了三种出厂配置给大家选择,以适应不同的使用需求.这三种基本配置分别是:整机、空机附加动力套件、空机;根据您购买的配置,请对照下图及第二页附件包清单来核对您的产品。

注：核对过程中，如果产生任何疑问，可以与销售商联系或者致电我公司垂询！（联系方式请参考说明书尾页）



附件包内容列表

整机、空机附动力

附件包 1

序号	配件名称	规格参数	数量
1	螺丝	PA 3*35mm	4
2	螺丝	PA 3*42mm	3
3	螺丝	PA 3*50mm	1
4	螺丝	PM 2*16mm	1
5	螺丝	PT 1.7*16mm	1
6	螺母	M2.0	2

附件包 2

序号	配件名称	规格参数	数量
1	钢丝绳	∅0.5mm L=800mm	1

附件包 3

序号	配件名称	规格参数	数量
1	Y线	L=100mm	3
2	夹头	∅1.2mm	2
3	螺丝刀柄	/	1
4	螺丝刀头	/	2
5	零件包	零件包1 零件包2	2

附件包 4

序号	配件名称	规格参数	数量
1	着舰钩	/	1
2	"A"字型炸弹挂架	/	1
3	机身天线	/	1
4	主翼天线	/	1
5	主翼固定塑料件 (前)	/	1
6	主翼固定塑料件 (后)	/	1

空机

附件包 1

序号	配件名称	规格参数	数量
1	螺丝	PA 3*10mm	4
2	螺丝	PA 3*35mm	4
3	螺丝	PA 3*42mm	3
4	螺丝	PA 3*50mm	1
5	螺丝	PM 2*16mm	1
6	螺丝	PT 1.7*16mm	2
7	螺丝	PWA 2*8mm	4
8	螺母	M2.0	2

附件包 2

序号	配件名称	规格参数	数量
1	钢丝绳	∅0.5mm L=800mm	1

附件包 3

序号	配件名称	规格参数	数量
1	Y线	L=100mm	3
2	夹头	∅1.2mm	2
3	螺丝刀柄	/	1
4	螺丝刀头	/	2
5	LED灯控制板	/	1
6	襟翼舵机控制钢丝	∅0.8mm L=105mm	2
7	零件包	零件包1 零件包2	2

附件包 4

序号	配件名称	规格参数	数量
1	着舰钩	/	1
2	"A"字型炸弹挂架	/	1
3	机身天线	/	1
4	主翼天线	/	1
5	主翼固定塑料件 (前)	/	1
6	主翼固定塑料件 (后)	/	1
7	整流罩	/	1
8	仿发动机装饰件	/	1

Install

Note:

1. When install, please read the manual carefully. if you have any questions, kindly contact with your distributor, or contact us on freewing@sz-freewing.com
2. the manual was based on ARF version as a reference.
3. **Before install, please refer to P12, check correctly the screw position.**

组装部份

提示:

1. 组装过程中, 请仔细对照说明书, 如有任何疑问, 可以联系您购买产品的经销商, 或者联系我们公司邮箱 freewing@sz-freewing.com 来寻求帮助。
2. 本说明书是以ARF作为参考制作。
3. 组装过程中, 请参考P12页面, 查看螺丝正确的应用位置。

As the right photo shown, prepare spareparts and install main wing.

首先, 如右图所示, 准备好零件, 拼装主翼。



Use Y wire to connect the following wire.

- left and right main wing servo
- left and right flap servo
- left and right electric retract

用三根Y线分别连接以下连接线:

- 左、右主翼舵机
- 左、右襟翼舵机
- 左、右电动起落架



Insert the carbon tube into the left and right main wing and piece together main wing.

将碳纤管插入到左、右主翼中, 拼合主翼。



Put down main landing gear by RC or other equipment.

利用遥控器或者其它设备, 放下主起落架。



Take down the cockpit.

取下机身座舱。



Assemble the main wing to fuselage, and sort out the connection lines.

将主翼安放在机腹。同时整理好所有连接线；



According to right photo, assemble main wing fixing plastic part.

根据右图所示，安装主翼固定塑料件。

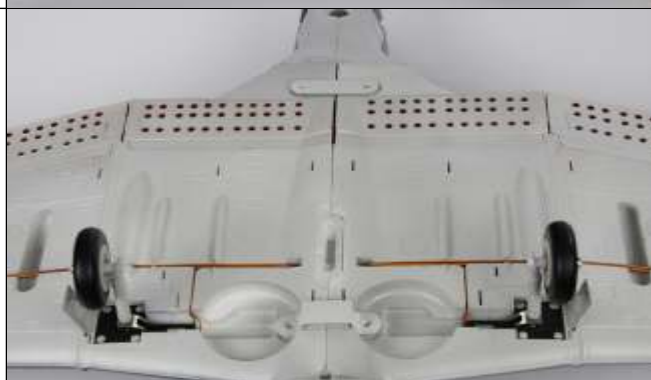

Fix the main wing by screws.

用螺丝固定主翼。；



Loosen screw as the photo shown.

松开尾翼舵机控制钢丝固定螺丝。

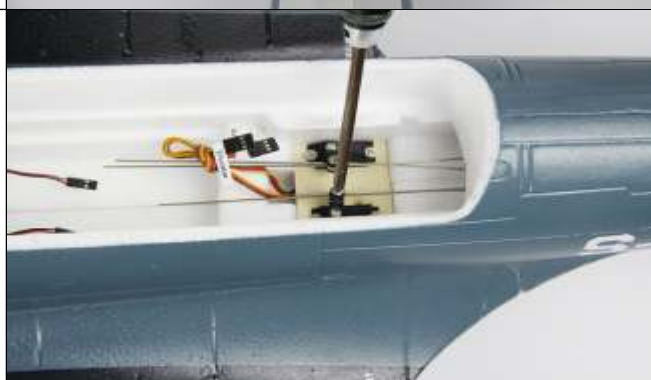

Pull out the metal wire on tail wing, for convenience to assemble tail wing.

拔出垂直尾翼控制钢丝，以方便尾翼的安装。



As the right photo shown, prepare spareparts to assemble tail wing.

如右图所示，准备好零件，安装尾翼。



Fix the elevator on the rear fuselage by screws.

用螺丝将平尾固定在机身尾部。



Insert the rudder.





插入垂直尾翼。



Turn over the fuselage, fix rudder by screws.

翻转机身，用螺丝固定垂直尾翼。



<p>Next, we begin to assemble bomber and tanks.</p> <p>接下来，我们开始安装炮弹及油箱。</p>	
<p>Fix the bomber ejection structure by screw and nut.</p> <p>用螺杆和螺母固定炸弹抛射机构。</p>	
<p>Assemble bomber.</p> <p>安装炸弹。</p>	
<p>Assemble tanks.</p> <p>安装油箱。</p>	
<p>Glue on the indicated position as the right photo shown, assemble main wing antenna and hook.</p> <p>右图所示位置涂装胶水；安装主翼天线及阻拦钩。</p>	

Glue on the indicated position as the right photo shown, assemble fuselage antenna.

在右图所示座舱位置涂摸胶水，安装机身天线。



At last, assemble antenna.

最后，安装天线。



Insert the rudder metal wire into servo arm, and adjust its length, then fix by screw.

插入垂直尾翼控制钢丝到舵机摇臂中，调节好钢丝长度，用螺丝固定。



Insert the left and right LED wire into LED controller, please refer to the right photo.

将左、右主翼LED灯线插入到LED灯控制板上。接入方法，请参考右图；



LED Controller Connection Diagram

LED灯控制板连接示意图

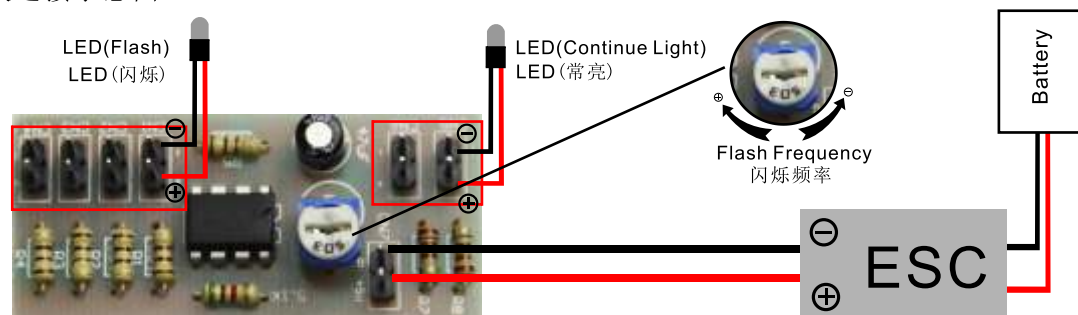

Connect the channels to receiver, and switch on transmitter and power on. After checking every servo is in the center, through adjust the length of control metal wire, center every servo surface.

将飞机各通道连接到接收机，打开发射机、接通电源。在确认所有舵机居中的情况下，通过调节控制钢丝的长度，居中所有舵面。



Use Battery

We use Fullymax 4S 2200mAh 25C battery to test, fly 3 minutes if full rate, so, we advise to use 4S 2200mAh 25C battery to fly. when use different size battery, the CG maybe change, you can through move battery to reach the correct CG.

电池的使用

我们在测试飞行时使用的是Fullymax 4S 2200mAh 25C电池。可以全油门飞行3分钟。所以，我们建议您使用4S 2200mAh 25C以上容量的电池来飞行。当选用不同规格的电池时，重心可能会改变。您可以通过向前、向后移动电池，达到配平重心的目的。

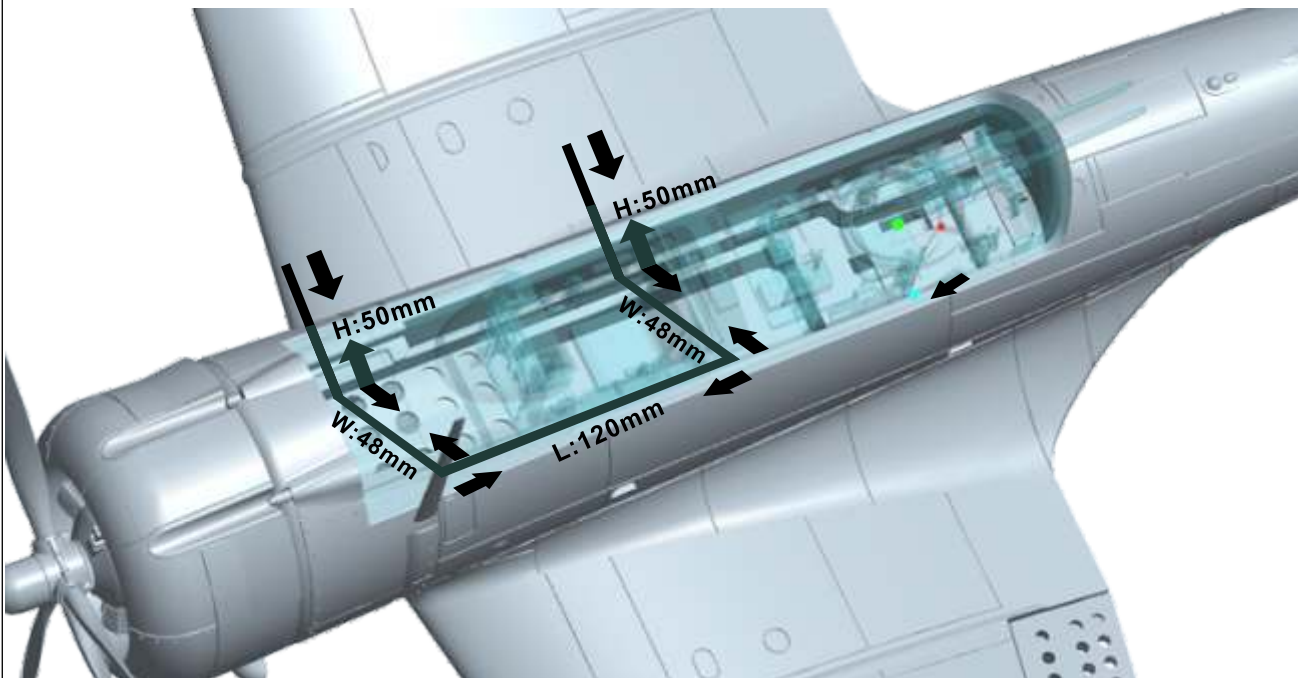

Control Surface Travels

Aileron travel relative to datum line:	+ 8 mm 30% Expo
	-10 mm 30% Expo
Taileron travel relative to datum line:	+10 mm 30% Expo
	-8 mm 30% Expo
Elevator travel relative to datum line:	+ 8 mm 35% Expo
	-10 mm 35% Expo

Operating instruction of Radio Control

1. Radio control include the transmitter and receiver.



2. Radio control function introduction.

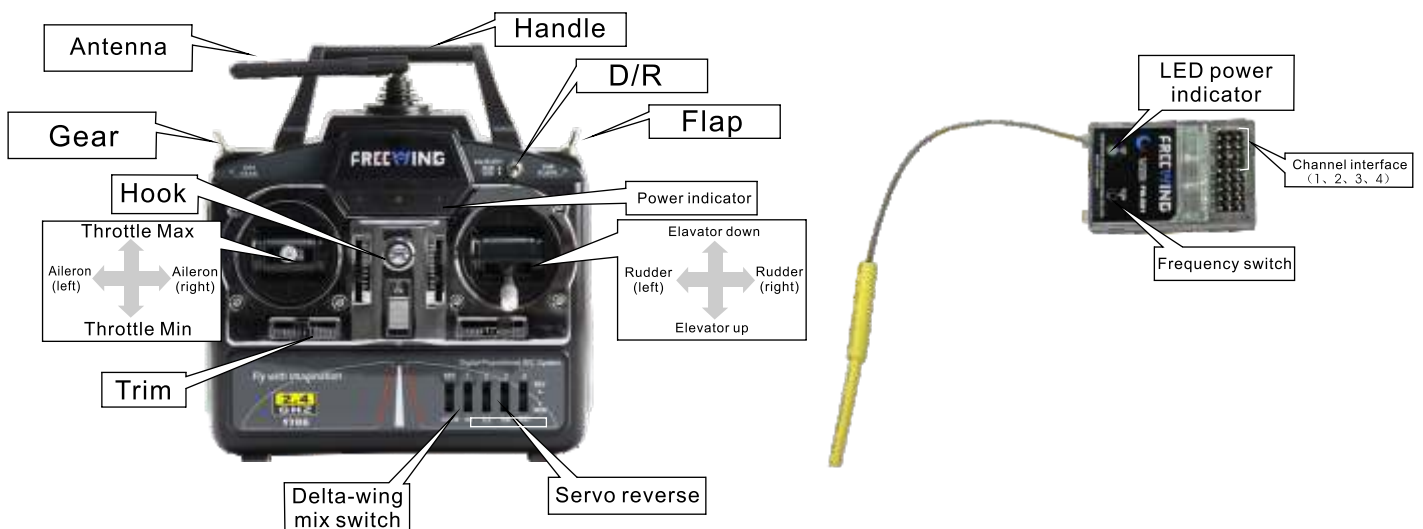

3.2.4G Radio control frequency method.

Note: the radio control has been established on the frequency treatment in factory, could use directly. In exceptional case, it need re-adjust frequency, please set as following:

- Press on the receiver frequency switch,
- While press on the receiver frequency switch, the receiver power on.
(Now, the receiver frequency signal light should be continue flashing.)
- Turn on the transmitter power switch
(Now, in transmitter panel, red light, yellow light, green light will be continue flashing)
- Stop to press on the receiver frequency switch
- After the success of the frequency, the receiver frequency signal light is on, not flashing.
The transmitter signal light is on, not flashing, it transformed to battery signal light

Douglas SBD-5 Dauntless Structure Diagram

结构分解图

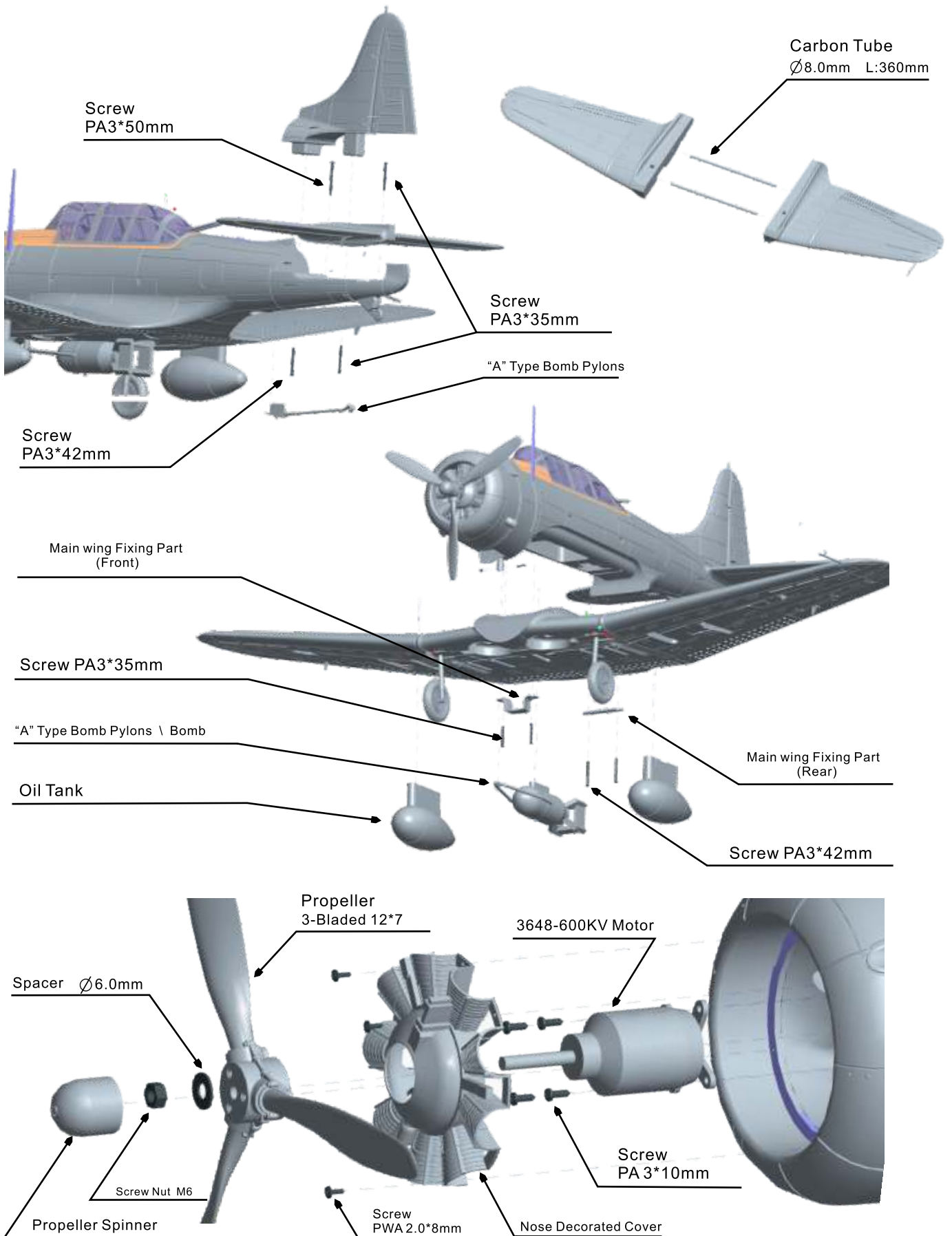

Motor Parameters

电机参数

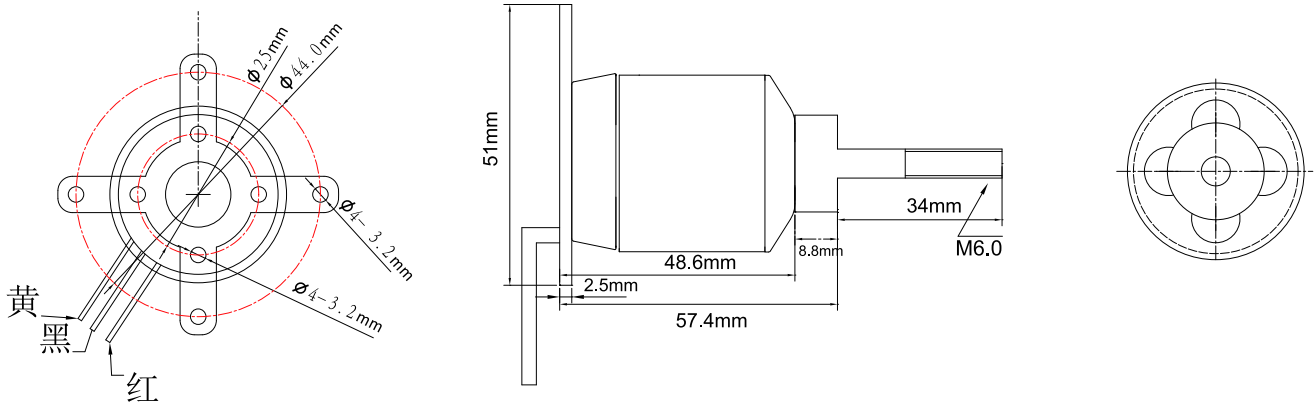

Model	KV Value	Volute (V)	Current (A)	Pull (g)	RPM	Weight (g)	No Load Current	Propeller	ESC
3648-600	600RPM/V	14.8	30	1900	9120	180	1.5A\ 11.1V	3-Bladed 12*7	40A

Preflight

After check everything before flight, as a beginner, we should pay attention of following issues, to make sure our flight is successful.

1. When use radio set, make sure switch on the transmitter power firstly, then power on the receiver.
2. Before flight, under power on condition, push up and down the throttle and check the motor/ESC work well.
3. Before flight, check well the plane's center of gravity. Correct CG is the key factor of successful flight. Please refer to P14 to check the center of gravity.
4. No matter take-off on the road or hand launch, we must upwind to take off.
5. After take off, if any unusual flight or hard to control, we should pull high the plane, then trim to adjust according to the actual situation to maintain it level flight.
6. When the transmitter alarm, you must end your flight as soon as possible and operate to its landing, to avoid the radio will be out of control since of low voltage.
7. If any damage in flight, please purchase the spareparts from your distributor or refer to www.sz-freewing.com to check.

飞行注意事项

在完成飞行前的检查之后，对于我们初学者，我们应该在飞行前及飞行中注意下面一些问题。这样，会使我们的飞行更加成功。

1. 在正常使用遥控设备时，必须保证先打开发射机电源，然后再将接收机通电。
2. 在飞行前，通电状态下，应反复上、下推动油门，检验马达与电子调速器的工作状态是否良好。
3. 飞行前，必须确认飞机的重心位置。正确的重心位置是获得成功飞行关键因素。请参考P14来确认飞机的重心位置。
4. 不管是选择滑跑起飞或者是手掷起飞，我们都应该迎风起飞。
5. 飞机起飞后，发现飞行姿态有异常或难以控制时，我们应当尽量拉高飞机，然后根据飞机的实际情况，调整飞机的微调开关。使飞机可以保持平飞。
6. 当发射机发出报警音后，应尽快结束飞行，操纵模型飞机着陆，避免低电压造成遥控设备失控。
7. 在飞行过程中，如发生损坏，请联系您的模型商购买配件。请参考我们的网站：www.sz-freewing.com查询。

重心

正确的重心，对于我们在首次飞行时非常重要的。请参考下面的重心标示图，来确认您的SBD-5的重心位置是否正确。

Center of Gravity

The correct CG is very important for our first flight. check your SBD-5 CG as follow picture.

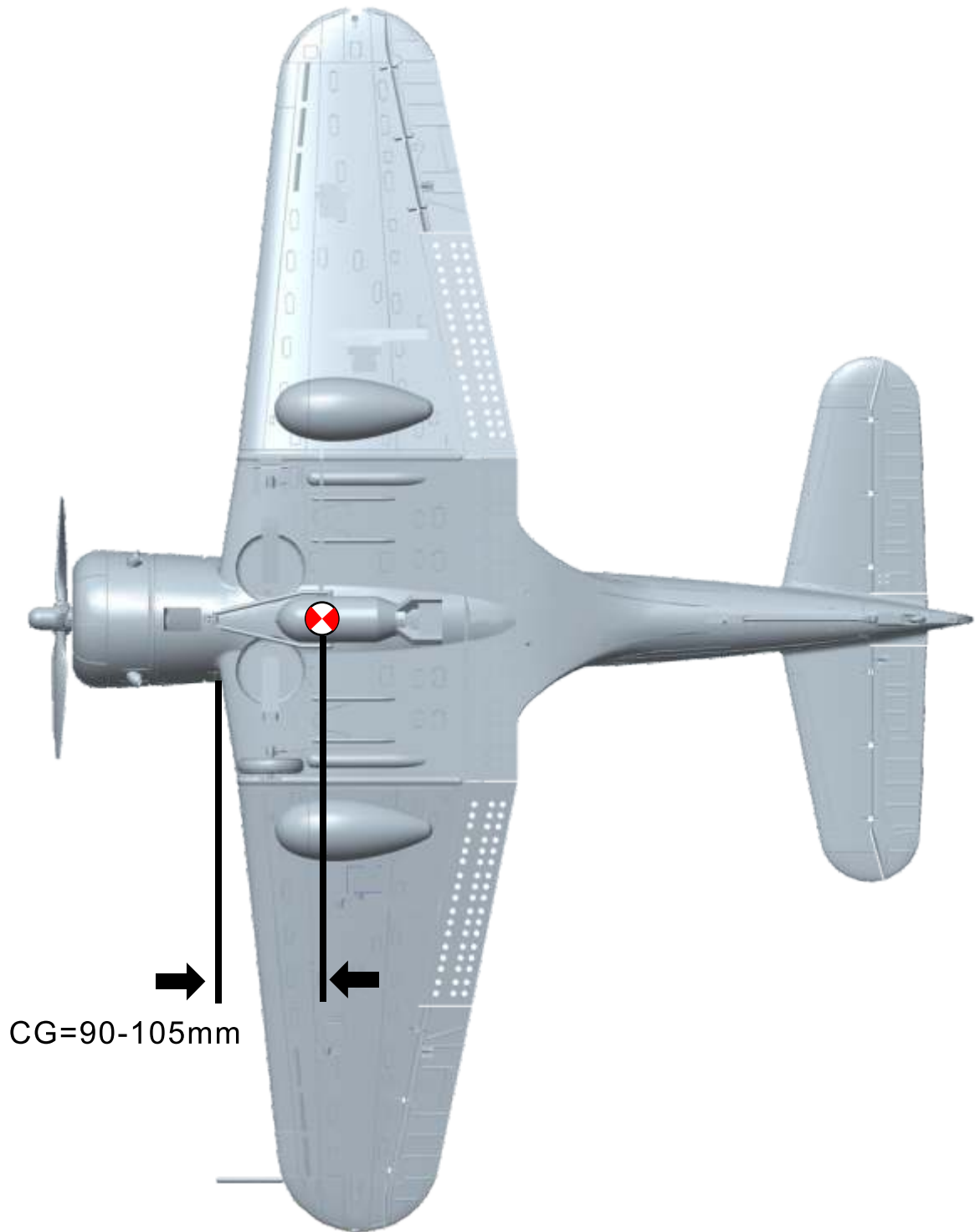



Have Fun!
We hope that you have many pleasant
flights with your Douglas SBD-5 Dauntless !



Shenzhen Freewing Model Co.,Ltd
HK Freewing Model International Limited

Add.:FeiYi Building,face to Labor Bureau, Fumin Middle Road, Dalang Town,
Dongguan City , Guangdong Province, China
Web: <http://www.sz-freewing.com>
Email:freewing@sz-freewing.com
Tel: 86-769-82669669 Fax:86-769-82033233